

Business Plan:

Toloue Mazrae Talaie

Now: Alchemist Green Technologies

Makers of Animal Waste Processing Machines



Table of Contents

Table of Contents	1
Executive Summary	2
Introduction	3
Market Size	4
Our Solution/Technology	4
Competitive Landscape	8
Human Resources	10
Facility Layout	12
Location	13
Production Equipment	13
Production Parts	14
Marketing Strategy and Plan	16
Key Success Factors	19
Intellectual Property Roadmap	20
Key Performance Indicators	21
Risks and Risk Mitigation	21
Governing Rules and Regulations	22
Investment Schedule	23
Financial Projections	24
Appendix A – Assumptions Behind Financial Projections	27
Appendix B – Pre- and Post-Treatment Analysis of Treatment	29
Appendix C – Advantages of Organic over Chemical Fertilizers	34
Appendix D – Real Estate Costs	36
Appendix E – Resumes	37

Executive Summary

Serious problems faced by the global population at the moment:

- The globe's need for food and agricultural products is increasing, which requires access to fertilizers that can revive the nutrients in the soil.
- chemical fertilizer production involves chemical processes that emit numerous byproducts such as SO₂ and CO₂, which are extremely harmful to the environment. Furthermore, use of chemical fertilizers over time results in buildup of certain un-consumed chemicals in the soil.
- The only sustainable type of fertilizer in the long run for our planet is organic fertilizers.
- Most farmers across the globe continue to use the archaic means of creating organic fertilizer – i.e. to place the manure in pools, with serious environmental repercussions as pathogens/germs will contaminate the surrounding environment and hazardous fluids will leach into the ground

Our solution uses contained chambers and uses energy efficient, proprietary technology to do the decontamination in less than 1 day rendering the output pathogen and odour free yet with the necessary nutrients for crops.

As per our extensive competitive landscape research, the only competitor serving Canada, with technology comparable to ours, in terms of speed, environmental impact, and liquid fertilizer generation, is FEECO international, whose product is priced at higher than \$1.3M for a 6-ton-per-day solution. Our \$500,000 price tag will be very attractive and allow us to gain attraction and entry into the market.

Our executive team is comprised of seasoned managers, sales and marketing experts, and HR and engineering specialists who have worked as a team extensively and built successful operations in the past. They know how to hustle – get employees excited and turn potential buyers into buyers too.

Cost of direct materials for each system produced will be \$216,000 and direct labour will be \$44,000 for total variable costs of \$260,000. Selling at the units at \$500,000 price point represents a gross margin of 48%. Operating expenses will be at \$1.2M for the first few years, assuming 5 to 9 systems will be built per year.

The cash flow breakeven is reached if 4 units are sold every year and accounting breakeven is achieved if 5 units are sold every year (which would cover depreciation and deferred salaries of founders in the first year as well).

The company will reach profitability in Year 2 and by Year 5 will have net after tax profits of \$773,646. In a very likely scenario, this amount will be used to increase founder's salaries but to also invest in automation, sales and marketing initiative, brand building, and further global outreach to export markets.

The company's goal is to invest in continuous R&D. Not only to reduce the environmental footprint of the system by reducing utility consumption even further (it is already very insignificant), but also to make the production process more efficient, quick, while maintaining high quality control standards, employee morale, and customer satisfaction.

Introduction

What's in the Name

Our proposed operating name in Canada, Alchemist Green Technologies, captures the problem our company has set out to solve in today's world.

The Problem

On the one hand, the globe's need for food and agricultural products is increasing, which requires access to fertilizers that can revive the nutrients in the soil. Crop rotation can only go so far in helping farmers and is not always an option. Eventually the soil is depleted of its key nutrients i.e. NPK (Nitrogen, Phosphorus and Potassium).

Now the problem is that chemical fertilizer production involves chemical processes that emit numerous byproducts such as SO₂ and CO₂, which are extremely harmful to the environment. Furthermore, use of chemical fertilizers over time results in build up of certain un-consumed chemicals in the soil which eventually make their way to underground water reserves – that is, contaminate our underground water supplies as well as our soil and environment.

The only sustainable type of fertilizer in the long run for our planet is organic fertilizers. Production of organic fertilizers is consistent with the concept of re-use, as it involves converting back manure from animals that consumed plants in the first place to recycle back those same NPK nutrients into the soil where they originated from. The diagram below captures this concept nicely.

Now, the problem our company has been able to solve is the fact that most farmers across the globe continue to use the archaic means of creating organic fertilizer – i.e. to place the manure in pools and let microorganisms digest them over a period of weeks and eventually convert the manure into fertilizer.

This again has serious environmental repercussions as pathogens/germs will contaminate the surrounding environment and hazardous fluids will leach into the ground, working their way into underground water systems.

Our solution uses contained chambers and uses energy efficient, proprietary technology to do the decontamination in less than 1 day rendering the output pathogen and odour free yet with the necessary nutrients for crops.

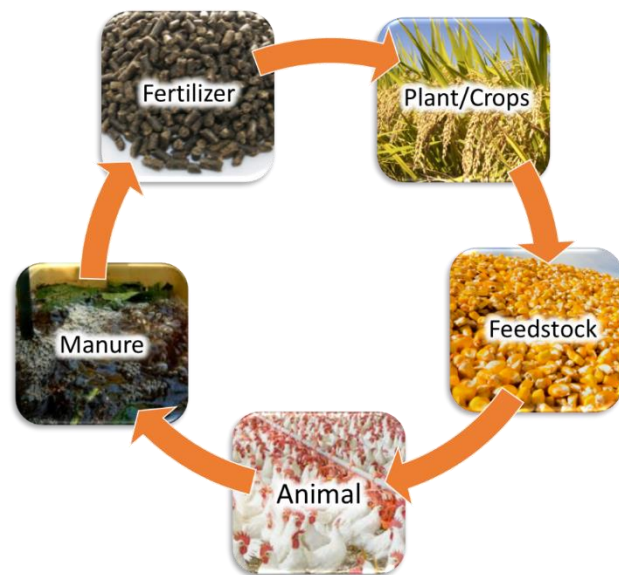

Market Size

Number of Manure-Producing Farms in Canada: 205,730¹.

In 2011, Canada had **205,730** census farms, a number representing a decrease of **10.3%** (or **23,643** farms) since the last census. Historically, the total number of census farms in Canada began to decline after 1941 followed by the accelerating urbanization of the 1950s. Nov 6, 2018

2016²:

Chicken egg production	2,008	+9.7% change from 2011 to 2016
Broiler and other meat-type chicken production	2,175	+11.0% change from 2011 to 2016
Dairy	10,525	-13.8%
Beef cattle	36,013	-3.7%
Hog	3,305	-4.8%

205,730 manure-producing farms is a huge market. Our firm will break even if we sell 5 systems per year, and each 6-ton-per-day system supports on average one to two farms.

The following are other related market sizes that will provide some perspective on the “organic” fertilizer market as well as the “liquid fertilizer” market:

- **“The Europe Organic Fertilizer Market** was valued at \$2,451 million in 2016, and is projected to reach \$3,260 million by 2023, registering a CAGR of 4.2% from 2017 to 2023.”³
 - *Organic fertilizers are derived from organic compounds such as animal and vegetable waste. These fertilizers are a rich source of primary nutrients, which include nitrogen, phosphorus, and potassium and help maintain the health of the crops. Furthermore, they increase the organic & humus content in the soil, provide nutrients for microorganisms in the soil, and restore the physical-chemical properties of the soil.*
- **“The Global Liquid Fertilizer Market** was valued at \$11,108 million in 2016, and is expected to reach \$13,530 million by 2023, registering a CAGR of 2.8% from 2017 to 2023.”⁴

Our Solution/Technology

Unlike most competing solutions that simply heat the manure until it all becomes solid fertilizer (i.e. moisture level down to 85% to 95%), our solution first separates the liquid manure (note, this is not water, it contains the same nutrients as the solid manure – such as Nitrogen, Potassium, and Phosphorus). Then we decontaminate each type using our proprietary technologies, which combine

¹ <https://www150.statcan.gc.ca/n1/pub/95-640-x/2011001/p1/p1-01-eng.htm>

² <https://www.agr.gc.ca/eng/animal-industry/poultry-and-egg-market-information/industry-indicators/number-of-farms-by-industry-type/?id=1384971854416>

³ <https://www.alliedmarketresearch.com/europe-organic-fertilizer-market>

⁴ <https://www.alliedmarketresearch.com/liquid-fertilizers-market>

piezoelectric waves, UV rays, infrared waves, special gassing mechanism, ozone injection, and other mechanisms to turn these wastes into germ-free, odourless fertilizers.

The liquid fertilizer will be excellent for farm and plant irrigation, but also can be packaged and sold in 1 gallon containers for sale at very attractive prices.

Therefore, the pain of the farmers to sell and transport the waste; or alternatively have micro-organisms compost it in uncontrolled pools that contaminate the environment and cause different types of environmental hazards; is converted into a profit-making opportunity – which, at a selling price of \$500,000 reflects a quick payback period for the farmers’ investments.

The advantages of our technology/solution includes:

- Speed (1 day for any batch vs. e.g. 2-3 days for Netherlands-based Dorset)
- Germ free output: It helps to eliminate any pathogenic agents
- Separates liquid and turns into liquid fertilizer as opposed to wasting energy to vaporize all the water content for a solid-only output
- Value creation:
 - o Analogous to turning copper into gold – hence the proposed word “Alchemist” in our name.
- It helps prevent environmental pollution (earth, water and air pollution)
- Filter-less technology means no need to worry about maintaining/cleaning/changing filters
- It helps remove unpleasant odor and color of animal waste
- It helps to meet the plants nutritional needs and improvement of soil fertility.

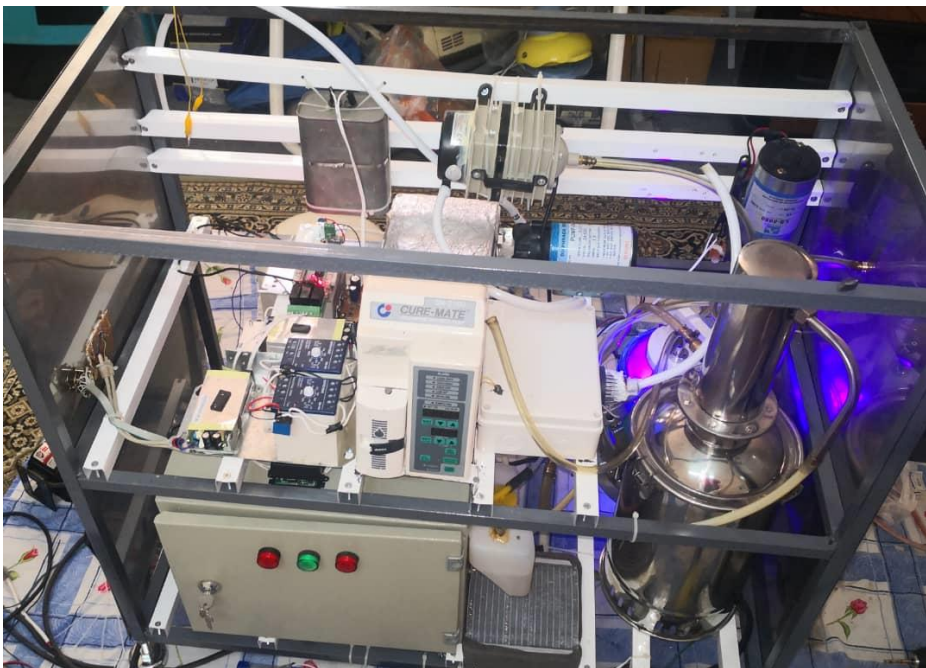

Our unique process has the advantage of minimally changing the chemical composition of the manure (which is rich in NPK – Nitrogen, Phosphorus, and Potassium) which are the top nutrients for plant growth and nourishment. This is proven through lab-tested results we present in Appendix B.

Note: Manure can be fed to system through different types of feeders

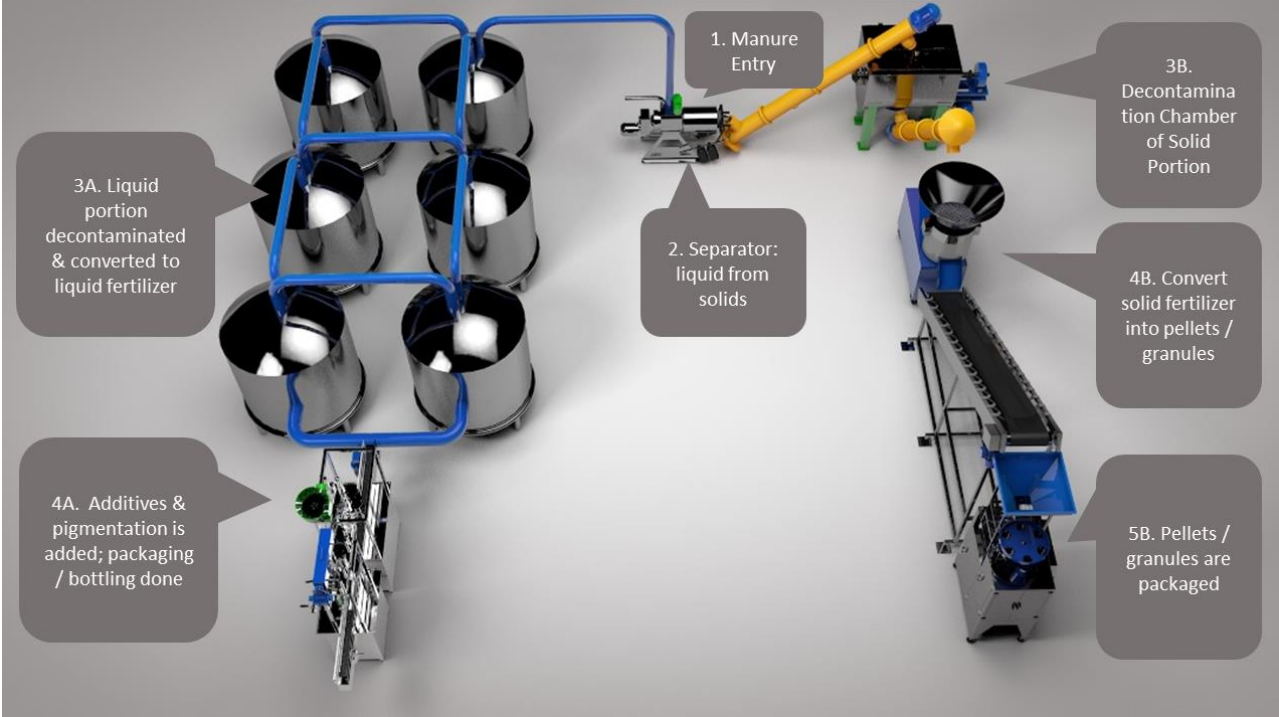
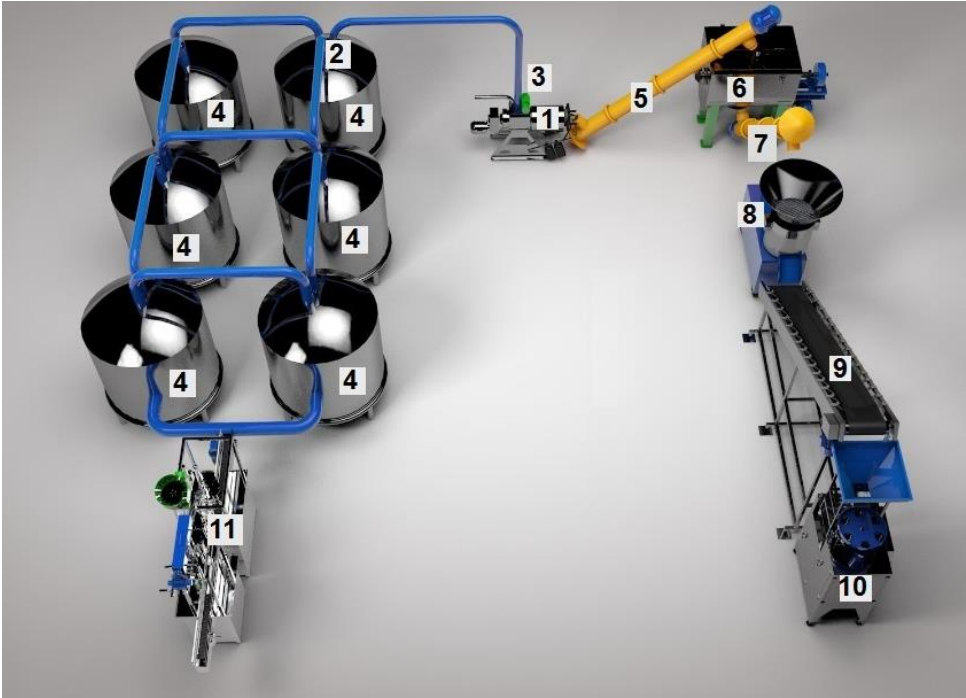

Diagram Legend:

- #1: Separator
- #2: Ozone and Electric Wave Generation and Injection Chamber
- #3: Transfer Pump
- #4: Liquid Waste Decontamination Chamber (includes conversion to fertilizer)
- #5: Solid waste transfer vessel
- #6: Solid waste decontamination chamber



#7: Solid waste transfer vessel toward granulation

#8: Pelleting / Granulation Machine

#9: Transfer belt of granules toward packing

#10: Packing of Solid Fertilizer Granules

#11: Packing of Liquid Fertilizer

The above system, as illustrated requires floor space of dimensions 20m by 20m.

Fully enclosed in a facility where one or more animal/dairy farmers have their waste processed, such facility will have minimum space requirements as displayed below:

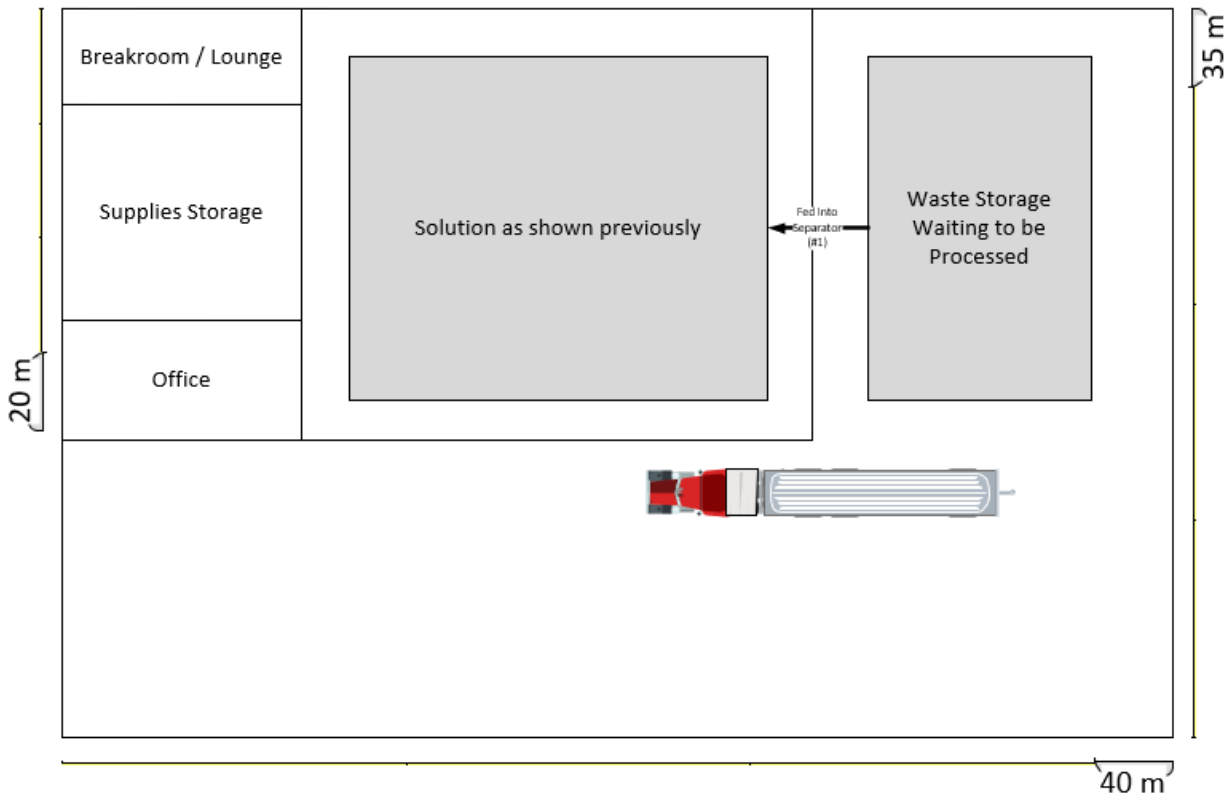

Cross Section of a Liquid Waste Treatment Chamber

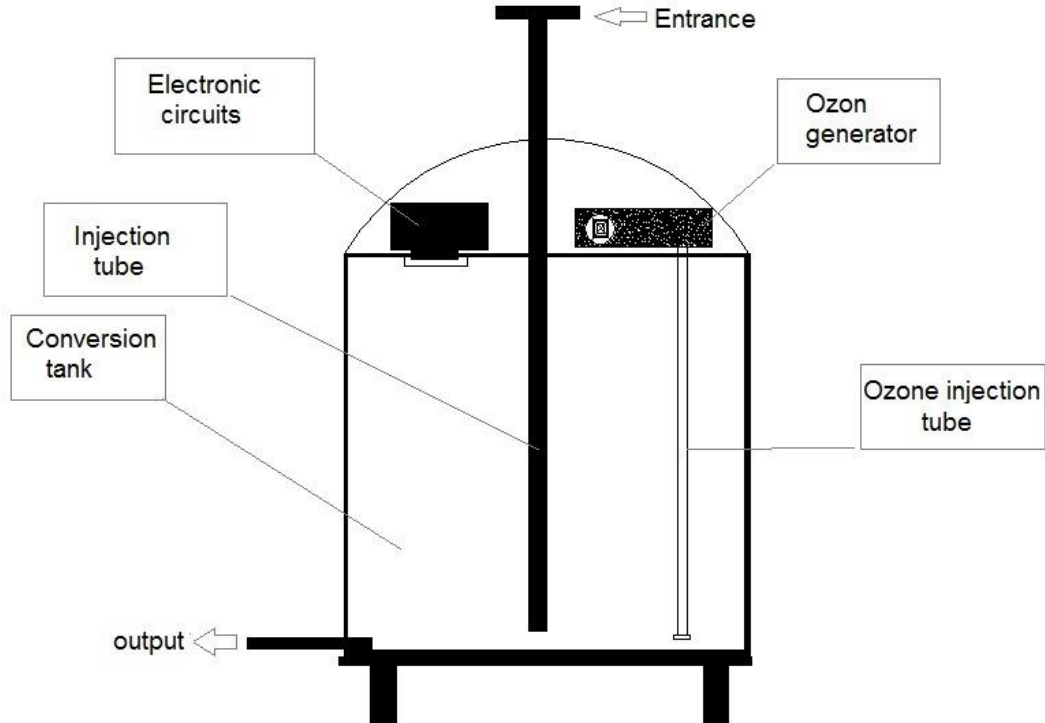

Competitive Landscape

Most competing solutions are rudimentary – a search on Alibaba does not return a single result of a machine that does not use micro-organisms for composting (with all the disadvantages such as taking weeks or months to process a batch, an output that is full of germs and odorous, etc.)

Only two companies come close to the level of transformation that our company achieves through its treatment technology.

Competitor #1 – FEECO International Inc

Established in the US in 1951, is the world's number one player in this area – with their manufacturing plant located in Wisconsin.

FEECO's offering, which in terms of feature set and waste conversion technology resembles our technology the most, is too expensive – at a price tag of \$2,000,000 USD = **2,700,000 CAD** for a system with processing capacity of 12 tons per day (500KG per hour) as quoted by Mr. Nick Reckinger (nreckinger@feeco.com), also available at (920) 468-1000. While at our company we can make 12-ton machines as well, we have decided to focus on 6-ton-per-day machines (i.e. 250KG of manure per hour) which will serve between 1 and 2 “average-sized” poultry farmhouses in Canada or an equivalent cattle farm. Smaller farms can pool their resources together, but the average farmhouse is our target market.

Competitor #2 – Dorset Green Machines

Dorset is another respected firm in this space, established back in 1984⁵ in the Netherlands with several offices around the world, including one in California.

They do not have a production facility in Canada.

Product

Dorset Poultry Manure Drying Plant (MB12/2D Drying plant)

- Input dry matter content of 50%
- Output dry matter content of 85%
- Output capacity of 2400 tons/annum

Consisting of the following items

- Belt dryer MB12/2D
- Agitator
- Discharge auger vertical
- Discharge auger
- Double Heat exchanger
- Air fans & air ducts
- Control System
- Fire sprinkler and detection safety system

Price (ex-works): 148,800 EUR

Optional items

- Input Bunker: (bunker- 8m³ capacity + discharge auger vertical) price (ex-works): € 20.400
- Dorset Pelleting Plant 400 kg/h price (ex works): € 149.500
- Biological air cleaner 15,000 Sm³/h price (ex works): € 39.100
- Chemical air cleaner - one section price (ex works): € 39.500

Total price including above options: 397,300 EUR = 620,781 CAD⁶

Disadvantages of their Manure Drying Plant

- The manure is dried up to 85% DM (Dry Matter) within 2 DAYS.
- The process vaporizes the liquid portion and does not result in separate liquid fertilizer.

Advantages of their Manure Drying Plant

- Cleaning the air of ammonia emissions (optional item)

⁵ <https://www.dorset.nu/green-machines/>

⁶ <https://www.google.com/search?client=firefox-b-d&q=397%2C300+eur+in+cad>

Competitor #3 - Eagle Green Energy

Alternative solutions are being used in North America as well. One example is the “poop digester” – the large silos (illustrated to the right) with input capacity of 4 tons of chicken manure per day⁷. The technology was developed by John Logan who worked with researchers and scientists at Mississippi State University to develop and patent “the first successful chicken poop digester”.

How this device works is as follows: the manure is heated, then mixed with bacteria, which produces the methane gas that is then converted into energy.

These digesters are being sold through Logan’s company, Eagle Green Energy at a price tag of **\$500,000 USD each**. The customers are located in Mississippi, Maryland, Delaware, and even in Italy, Australia and India.



Human Resources

Executive Team

The following comprises the management team at our new startup. For resumes please see Appendix E.

	Mohsen Khalaj <ul style="list-style-type: none">• CEO• Head of R&D
	Alireza Moradgholi <ul style="list-style-type: none">• VP Sales and Marketing
	Mahtab Rashvand <ul style="list-style-type: none">• Head of HR
	Ali Rashvand <ul style="list-style-type: none">• VP Operations

⁷ <https://www.npr.org/templates/story/story.php?storyId=125640525>

Other Personnel

Position Titles and Salaries will be as follows:

Role	# Employees (5 Units/Yr)	Salary per Employee	Total Salary for Role
CEO & R&D Lead	1	80,000	80,000
Assistant to the CEO / Receptionist	1	38,000	38,000
VP Operations	1	70,000	70,000
Plant Manager	1	60,000	60,000
Welder	2	42,000	84,000
General Labourer	5	30,000	150,000
Electronics Design Engineer	0.5	76,000	38,000
VP Sales and Marketing	1	60,000	60,000
Marketing Associate	0.5	51,000	25,500
Sales Associate	1	60,000	60,000
Director of Finance	1	80,000	80,000
Treasurer	0.5	70,000	35,000
Accountant	0.5	57,000	28,500
VP HR	1	60,000	60,000
# Employees:		17	Salaries: 869,000

Organizational Chart

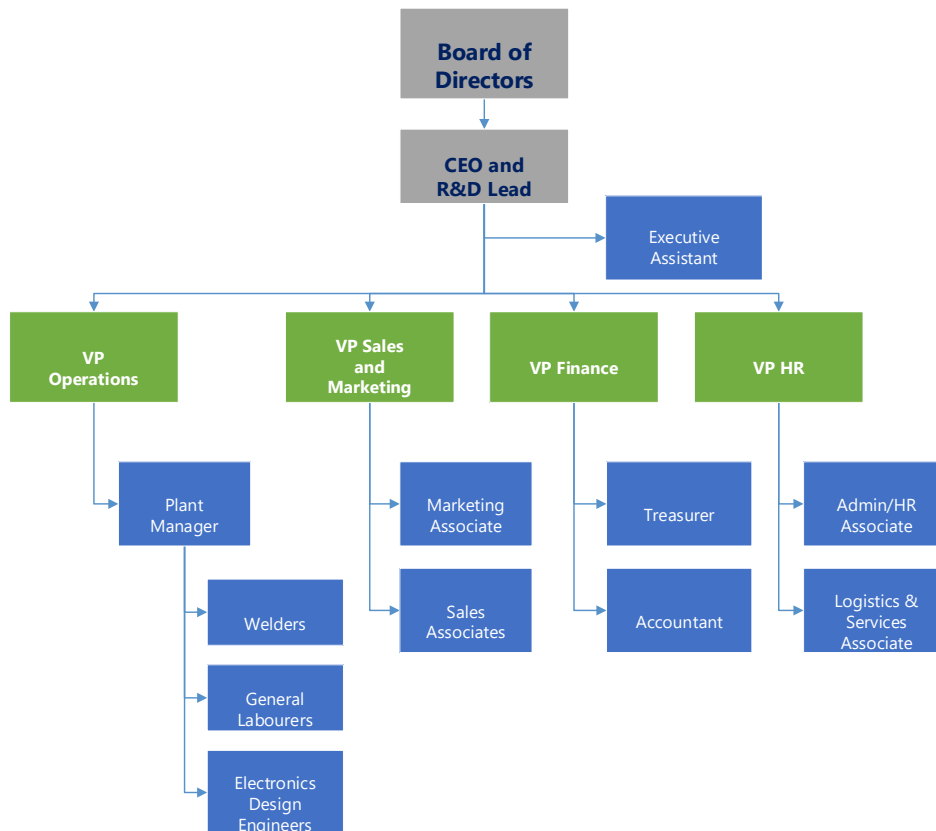

Facility Layout

The following facility layout (total area of 17,000 SF) will allow for work on five products simultaneously.

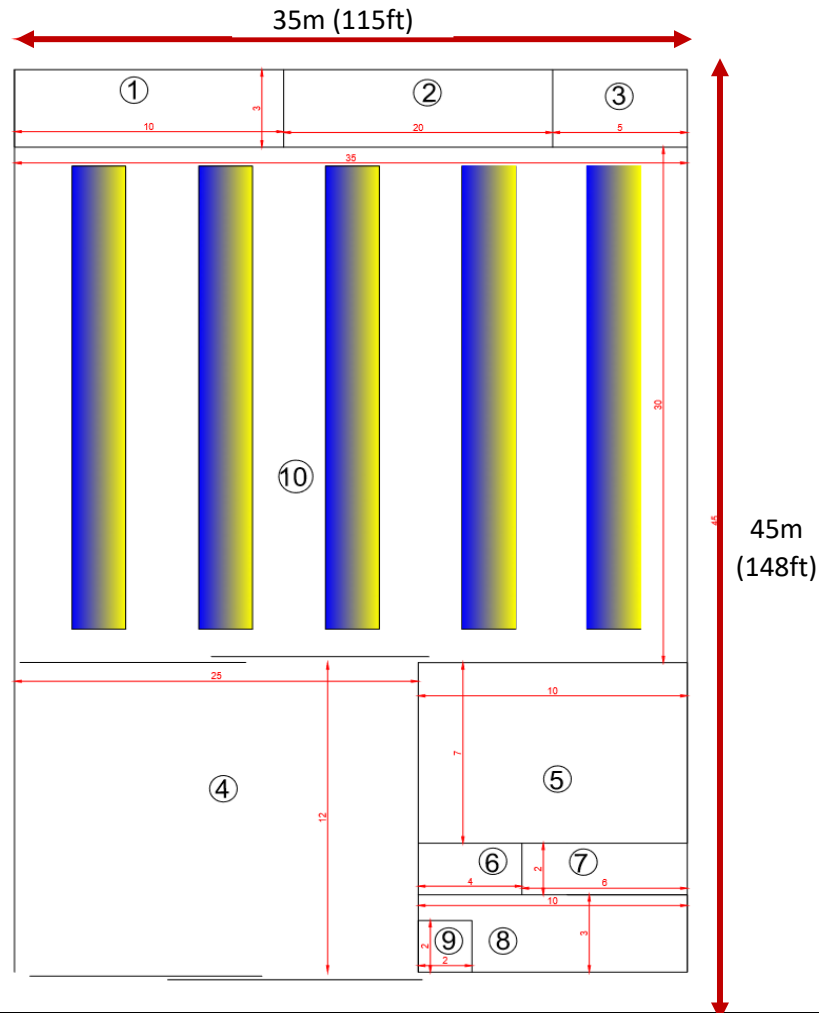

ID	Title	Description / Notes
1	Lab & Electronics Stock Room	Used for production of circuits and stocking electronic parts; accessible to Area 10.
2	General Storage Room	In the centre to maximize availability to all 5 production lines.
3	Janitor's Room & Washrooms	Washrooms for use by production floor staff; also houses cleaning tools.
4	Yard	Outdoor space - can be used for storing purchased materials.
5	Offices and Cafeteria	In 2 stories - first floor houses the kitchen and cafeteria; second floor houses conference room and two office rooms and a relaxation lounge for staff.
6	Locker Room Washrooms	Located in the Locker room for staff convenience and use.
7	Locker Room Showers	Located in the Locker room for staff convenience and use.
8	Locker Room	In 2 stories - first floor houses lockers and closets and washing machine and dryer for work clothes; the second floor is in-house dorm for workers.
9	Security Room	Used to control/record people passing through (in/out) and to ensure security of entire complex; located in front of the entrance to the building for security officers.
10	Production Floor	The main production area with capacity for 5 simultaneous products in progress. The space is designed to minimize energy waste and maximize worker productivity.

Location

Regardless of the region our manufacturing plant will be located in, the specific locale should have access to a port and railway to minimize costs of transportations of parts coming in, and completed units leaving for customer site.

Production Equipment

Expensive Equipment (Greater than \$200)

1. Sheet metal bending machine – 1 set – **\$20,000 CAD** (including delivery)



CNC Bending Machine ,Sheet Metal Bending Machine Price,press brake bending machine

FOB Reference Price: [Get Latest Price](#)

>=1 Sets
\$12,288.78

Lead Time:	Quantity(Sets)	1 - 1	>1
	Est. Time(days)	15	Negotiable

Customization: Customized logo (Min. Order: 1 Sets)
Customized packaging (Min. Order: 1 Sets) [More](#) 

Samples: \$12,288.78 /Set | 1 Set (Min. Order) [Buy Samples](#)

2. Two-Ton Overhead Crane – 1 set – **\$11,676 CAD** (including delivery)⁸



2 ton mini hoist manual single girder overhead crane

2-9 Sets **US\$6,950.00** >=10 Sets **US\$6,690.00**

Application:

Rated Loading C...

Model Number: PWL10 US\$6,950.00

Warranty: **1 YEAR** for machinery warranty

3. Cut-off saw – 1 set - **\$280**⁹

⁸ https://www.alibaba.com/product-detail/2-ton-mini-hoist-manual-single_1600056594759.html

⁹ <https://www.homedepot.com/p/DEWALT-15-Amp-Corded-14-in-Cut-Off-Saw-D28715/100634624>

Other Equipment

Adjustable spanner	2 units	Locking plier	2 pcs
Air compressor and accessories	1 set	Manual drill	1 unit
Air drill	1 unit	Pliers	2 units
Aviation snips	1 pcs	Saw bow	2 units
Bench Vise	2 pcs	Screw driver	3 sets
Caliper	1 pcs	Set of ring and flat wrench	2 sets
Cargo cart	1 unit	Socket wrench set	1 set
Circlip Pliers	1 pc	Torque wrench	1 unit
Cordless drill	1 unit	Torx key wrench	1 set
Electronic tool set	1 set	Voltage tester	3 units
Hammer and Sledgehammer	2 units	Wire cutting pliers	2 pcs
Hand riveter	1 unit	Wire stripper	1 pcs
Hex key	2 sets		

Altogether the production equipment are expected to cost **\$35,000** to procure, deliver and install.

Also, office equipment such as desks, computers, printers and furniture are estimated to cost **\$30,000**.

Production Parts

The following is a list of parts needed in order to make a 6-ton-per-day model of our machine:

Part	Qty	Unit	Total (CAD)	Brand	Country of Origin	Model and Description
Solid-Liquid Separator	1	Unit	65,000	Yushunxin	China	Solid-liquid separator
Storage Tank Electronic Circuits	3	Sets	23,000	SCHNEIDER	France	Part of the invention (involves modifications from original part)
Electronic Parts for the Liquid Portion	1	Set	20,000	SCHNEIDER	France	Part of the invention (involves modifications from original part)
Liquid Fertilizer Filling Machine	1	Unit	20,000	Xinyuan(Sinran)	China	Xinyuan 500ml and 250ml Spray Liquid Fertilizer Filling Machine For Bottles
Liquid conversion tank	9	Units	13,500	-		Material: polyethylene, with 2000 L capacity
Electrical Panel and Equipment	1	Unit	12,014	SCHNEIDER	France	List of parts are attached
Ozone Generator	3	Units	12,000	Allied Power	China	800g/h prozone ozone generator
Solid Waste Chamber	3	Units	10,750	-		Body of steel with 3mm sheet
Dry Fertilizer Packaging Machine	1	Unit	8,000	SunChon	China	Model: SUN-160G
Granulator Machine	1	Unit	5,417	Dadi Machinery	China	Flat die pellet mill fertilizer granulator
Open discharge tank	1	Unit	4,833	-		Hand-made pool with concrete structure and PE surface layer
Belt Conveyor	3	Units	4,750	-		For moving fertilizer. Lenth 6 m, width: 70 cm
Heating Element	10	Pcs	4,667	RICCO	Italy	3000 Watts
Pump	12	Units	3,800	Pentax	Italy	CR100 230V - Code: 022-320
Engine and Gearbox	3	Units	3,000	Siemens	Germany	Motox/Simogear spur gearboxes-available for motor power up to 200 kW output speeds of 0.06 to 1,088 rpm output torque up to 20,000 Nm
Transmission pipes	50	Meters	1,025	-		Material: steel, diameter: 2 inches, thickness: 2mm
Duct	60	Meters	850	-		5 cm diameter
Pyrex Tube	20	Pcs	810	Vatti	China	Diameter: 120mm, thickness: 9mm, length: 1.5 m
Fan/Blower	40	Units	767	KORMAS	Turkey	Model: BE0000973
UV lamps and circuits	9	Sets	668	PHILIPS	Germany	230 nano meters
Electrical Wire	20	Rolls	533	HEW KABLE	Germany	Fire resistant cable number 2.5 & 1.5
Ultraviolet lamp	9	Sets	353		Germany	750 Watts
Polyethylene Pipe	120	Meters	260	-		Polyethylene Pipe PE100 with 2 inches diameter

Total: 215,996

The Electrical Panel and Equipment item from above has been broken down as per the following list:

Part	Qty	Unit	Total Price (CAD)	Description
Capacitor	30	units	3,625	45 micro
Touch screen panel	1	units	2,500	12 inches
Controller board	1	units	1,050	220V- output: 32
Main switch	1	units	813	500 Amp, Automatic
Electrical enclosure	1	units	583	
Control transformer	2	units	500	380 to 220
Trigger transformer	6	units	490	Output: 220
Contactora	6	units	360	400Amp, 24V, 3 phase
Fuse	12	units	350	25 Amp
8 kW diode	8	units	267	Model: em3327cw
Electrical panel light	24	units	260	
Heat sink and fan	12	units	220	12 Volts
Motor Starter	2	units	163	Power supply: 380Amp 24 and 120 Amp
Push Button	12	units	158	
Seperator base	20	units	130	
Electrical panel switch	1	units	125	
Residual-current device	5	units	117	25 Amp
Phase protector	3	units	90	
Control switch	1	units	64	
Phase monitor relay	1	units	57	3 phase
C profile rail	6	units	48	
Rail mount terminal block	100	units	25	
Relay board	1	units	14	30 Channels- 24V
Circuit base	1	units	6	

Total: 12,014

Marketing Strategy and Plan

Low-volume, high-value business model, it relies on direct sales approach as opposed to mass marketing campaigns. However, awareness building initiatives like tradeshow will be extremely beneficial too.

The marketing efforts, from positioning of the firm among competitors to branding and promotion will focus on the following market segments:

- Cattle farmers (e.g. AlbertaBeef.org)
- Poultry farmers (and their associations) – e.g. in Ontario there is OntarioChicken.ca
- Dairy farmers
- Chicken Egg Producers

Value Proposition

The quickest conversion of Animal Waste into Organic Fertilizer (Solid & Liquid Fertilizers) with minimal energy consumption and maximum environmental friendliness technologies.

As previously noted, the zero viral/bacterial content, exceptional speed of waste treatment and conversion, and much higher capacity for input waste, results in effective processing capacity that is around 30X that of the next best product in the world (see Competitive Landscape). Not only does this product process more waste, but it means huge savings in terms of real estate requirements, operational waste (unnecessary moving of staff between multiple machines instead of servicing only one). This product is also very well-priced. Instead of being priced at \$600,000 to \$1,300,000 per set like other comparable solutions, we are priced at \$500,000.

The following are the two most effective ways of targeting and acquiring customers:

Direct Sales

The goal of direct marketing will be to take the potential customer on a journey (of stages) best described by the acronym AIDA: Awareness, Interest, Desire, Action. Traditional best practices in terms of generating qualified leads (e.g. municipalities in Canada and the United States with the highest incoming agricultural waste), then qualifying and following up further through the sales funnel will be applied; best in class tools like Salesforce will be used to maintain a professional conduct and optimize the sales cycle and effectiveness.

Trade Shows

Participating in relevant trade shows and conferences will help build awareness, relationships, and the brand. The following are events being held across Canada that the company will plan to participate in.

In tradeshow, we will pursue two goals:

1. Try to find customers for our solution – this means talking to Animal and Dairy Farmers' Associations and Cooperatives
2. Agricultural Farmers – so they become aware of the brand of liquid and pelletized fertilizers that our machines produce and we can provide referral to them as to which farmers (our customers) these entities can buy organic fertilizers from. This way we will be building demand from the

ground-up as well. Animal and dairy farmers would appreciate buying machines from us that produce fertilizers that are associated in the market with concepts like organic and ecofriendly practices.

Event	Date	Location	Description	Participants
Canada's Farm Progress Show ¹⁰ (Tradeshow)	Usually in June	Regina	Connecting local producers and international customers with the latest in dryland farming equipment, technology, and innovation.	40000 visitors 700 exhibitors
Canada's Outdoor Farm Show ¹¹ (Tradeshow)	Usually in September	Woodstock	Highlighting the most innovative and technologically advanced agricultural products and services.	40000 visitors 750 exhibitors
Canadian Waste and Recycling Expo/ Municipal Equipment Expo ¹² (Tradeshow)	Usually in October	Toronto	Displaying products such as the latest technologies, equipment and services for the waste, recycling and public works markets.	20,000 - 50,000 Visitors 500+ Exhibitors
Zero Waste Conference ¹³ (Conference)	Usually in October	Vancouver	A future without waste: mobilizing for success in the circular economy.	2000 - 5000 Delegates 10-50 Exhibitors
Manitoba AG Days ¹⁴ (Tradeshow)	Usually in January	Brandon	Exposition of agricultural production expertise, technology, and equipment.	20,000 - 50,000 Visitors 500+ Exhibitors
Pacific Agriculture Show ¹⁵ (Tradeshow)	Usually in January / February	Abbotsford	Showcasing the latest and most innovative equipment and technology for the agriculture industry.	20,000 - 50,000 Visitors 500+ Exhibitors
AG Expo ¹⁶ (Tradeshow)	Usually in February	Lethbridge	Showcasing new product launches & the latest tech in the agriculture industry.	18000 Visitors 350 Exhibitors
London Farm Show ¹⁷ (Tradeshow)	Usually in March	London	Showcasing the latest products and services in agriculture.	20,000 - 50,000 Visitors 500+ Exhibitors
Ottawa Valley Farm Show ¹⁸ (Tradeshow)	Usually in March	Ottawa	Offering the latest in merchandise and services for farmers and other rural residents.	20,000 - 50,000 Visitors 500+ Exhibitors

¹⁰ <https://www.myfarmshow.com>

¹¹ <https://www.outdoorfarmshow.com>

¹² <https://waste-recycling-expo-canada.us.messefrankfurt.com/canada/en.html>

¹³ <http://www.zwc.ca>

¹⁴ <https://www.agdays.com>

¹⁵ <https://www.agricultureshow.net>

¹⁶ <http://ag-expo.ca>

¹⁷ <https://www.westernfairdistrict.com/london-farm-show>

¹⁸ <http://ottawafarmshow.com>

Establish the Company as a Thought Leader

Through its official blog (as posted on its website as well as Twitter and LinkedIn), the company will demonstrate to the public as well as potential clients its commitment to the mission of making waste processing fast, inexpensive, and environmentally friendly.

Authoring whitepapers and presenting them at conferences, such as the Zero Waste Conference listed in the previous section is another way of getting in front of industry enthusiasts and participants.

Other non-academic multimedia items such as video recordings (of municipalities using the device to process organic waste) can be converted for consumption in different formats such as documentaries or short case study videos – available to everyone on Youtube, Netflix, and other outlets.

The company PR personnel can participate in environment and sustainability-focused TED talks, interviews and other opportunities for exposure.

Other, complementary marketing efforts will include the following promotional activities:

Promotion - Offline

There is an opportunity for strategic partnership and cross-promotion with other waste management service and product providers such as sellers of waste handling tools and waste collection services.

There are of course the standard offline advertising methods that should be leveraged such as placing ads in relevant publications in the fields of agriculture, environmental stewardship, and waste management.

Promotion – Online

The most effective and high-ROI online marketing methods are PPC (Pay Per Click) advertising on Google and Facebook platforms as well as impression based ads on Linked In. Ads will be created so that only users searching for related solutions/services across North America will see the ads. Costs per click can range from 5 cents to 50 cents, which means every \$1,000 in budget can fund anywhere from 2,000 to 20,000 *clicks*, which means Google/Facebook will potentially show the ad 10X that number (i.e. 20,000 to 200,000 impressions) in order to generate those clicks. Therefore, a \$1,000 investment can potentially generate up to 200,000 impressions of the ad to the perfect demographic audience in the geography we specify.

Facilitating Sales

Since the company produces high-value products, the buyers should have an assurance that they are purchasing a quality, defect free product.

To make the purchase decision less risky for customers, the company will offer an 18-month Parts Guarantee as well as a warranty of 10 years provided that the machine has been used under the guidelines provided and has received the semi-annual preventive maintenance routinely.

Furthermore, the company will register with regional Better Business Bureau organizations in order to demonstrate the company's commitment to customer satisfaction and delivering only fully inspected

Pricing

The company will sell each complete animal waste transformation unit (including processing of Solid Waste into granules and Liquid Waste into Liquid Fertilizer) for \$500,000 CAD, which is highly competitive and priced to penetrate the market. The following are prices offered by similar products in the market:

- US-based FEECO International Inc sells each complete unit at \$2,700,000. This is the only unit in the market that processes waste as quickly as our technology (i.e. 1 day). Of course, this price tag is for a 12-ton-per-day solution. For 6-ton-per-day the price will be at least twice as much at **\$1.3M**.
- Netherlands-based Dorset Green Machines. Their complete solution sells for **\$620,780** Ex-Works. There are two main disadvantages with their system:
 - The manure is dried up to 85% DM (Dry Matter) within 2 DAYS (ours is twice as fast)
 - The process vaporizes the liquid portion and does not result in separate liquid fertilizer.
- US-based Eagle Green Energy which uses large silos as “poop digesters” and sells each for **\$700,000**.

Among the above competing solutions, which we have extensively elaborated on in the Competitive Landscape section of this report – *note: we are not competing with cheaper, low-tech systems that use micro-organism based pools that take weeks to process waste and have huge environmental footprints – the only one with technology comparable to ours, in terms of speed, environmental impact, and liquid fertilizer generation, is FEECO international, whose product is priced at higher than \$1.3M* for a 6-ton-per-day solution. Our \$500,000 price tag will be very attractive and allow us to gain attraction and entry into the market.

Key Success Factors

IBIS World¹⁹ lists the following as KSF's for companies that manufacture chipping & grinding machinery:

Environmental compliance – Manufacturers face a range of regulations regarding the generation and disposal of hazardous wastes. Failure to meet compliance can increase operating costs.

Effective quality control – The ability to control quality and minimize faulty products reaching the market will help increase brand loyalty through perceived reliability.

Proximity to key markets – Successful manufacturers locate close to raw material deposits and the main sources of demand.

Automation – Like most manufacturing activities, the ability to automate processes reduces wage costs and increases efficiencies, thereby improving profit margins.

¹⁹ Witter, D. IBISWorld Industry Report OD5425: Chipping & Grinding Equipment Manufacturing in the US. 2015.

Intellectual Property Roadmap

While it will not be possible to patent the manure treatment process as a whole, parts of the process and aspects of it will be patentable. For instance, the optimal design of our circuitry, which utilizes very little energy to generate fast-treating and high capacity manure transformation capability, as well as the configuration of actuators, wave emitters and other strategic parts will be patented as well.

To illustrate the level of specificity of the patents granted in this space, we provide some examples:

1. **“Enhanced Fertilizer Granule”**, US Patent US20100326151A1, applied for by FEECO International Inc and granted and published in 2010. Here’s an abstract of what it entails:

“An enhanced fertilizer product comprised of nutrients and inert solids wherein the nutrients and inert solids are derived from a source material. The nutrients in the source material are collected with a nutrient capture process. The fertilizer product is agglomerated.”²⁰

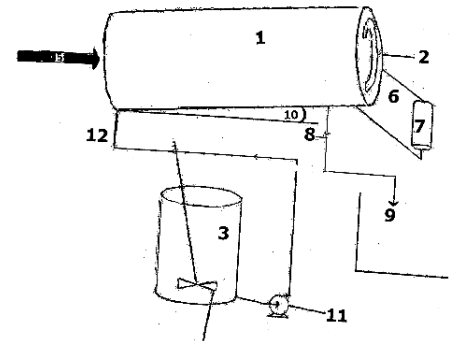

2. **“Material Handling System and Method”**, US Patent US5419498A, which was granted to FEECO International Inc in 1993 and expired after 20 years by default, in year 2013. Here’s an abstract of what it entails:

“A material feeding system and method generates a specified continuous output from a variable quantity of discrete and separated units of input.”²¹

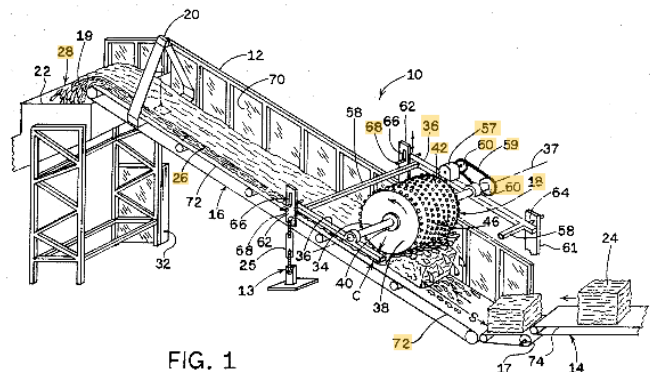
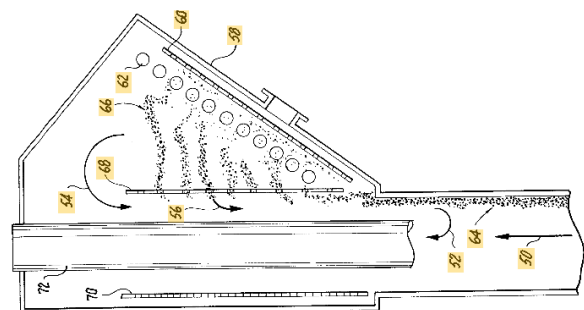

FIG. 1

3. **“Drying and Cooling Unit”**, US Patent US6584700B1, granted to FEECO International Inc in 2000, and expected to expire this year in 2020. An excerpt from the abstract follows:

“A dryer-cooler unit comprising a single vessel wherein drying and cooling occur. The unit comprises a rotary dryer and a stationary discharge hood. Cooling air is distributed through the discharge hood.”²²



²⁰ <https://patents.google.com/patent/US20100326151A1/en?assignee=feeco&oq=feeco>

²¹ <https://patents.google.com/patent/US5419498A/en?assignee=feeco&oq=feeco>

²² <https://patents.google.com/patent/US6584700B1/en?assignee=feeco&oq=feeco>

Key Performance Indicators

The following KPI's will be monitored by management in order to keep abreast of any deviations from an optimal production operation. The goal will be to improve costs, quality, and innovation year after year. The list has been handpicked from an extensive list at KPIdashboards.com²³.

- Asset utilization
- Capacity utilization
- Compliance rates (for government regulations, etc.)
- Customer satisfaction
- Cycle time
- Demand forecasting
- Faults detected prior to failure
- Labor as a percentage of cost
- Manufacturing cost per unit
- Mean time to repair
- On-time orders
- On-time shipping
- Overtime as a percentage of total hours
- % decrease in inventory carrying costs
- % decrease in production-to-market lead-time
- % increase in productivity
- % increase in revenues
- % material cost reduction
- % reduction in downtime
- % reduction in inventory levels
- % reduction in manufacturing lead times
- % savings in costs
- % savings in inventory costs
- % savings in labor costs
- % savings in transportation costs
- Quality improvement (first-pass yield)
- Quality tracking-six sigma
- Reduced time to productivity
- Savings in inventory carrying costs
- Supplier trending
- Time from order to shipment
- Work-in-process (WIP)

Risks and Risk Mitigation

Risk	Mitigation Mechanism
Copycat / IP theft / Corporate Espionage	Because the circuitry and assembly of the machine can be reverse-engineered, the only true way for protection is to patent the industrial design and process, as well as protect the electronic circuit design.
Competition – Existing Players	Current players may provide temporary discounts to make our products less attractive, however, the high affordability of our solution (compared to FEECO for example), and 3X faster processing than Dorset, is not something that can be copied immediately.
Competition – New Entrants	Entry to this field requires specialized technical know-how and significant investment; since barriers to entry are high, this threat is low. Patents and continuous improvements keep us always among the top players.
Cost of input components increasing	<ol style="list-style-type: none"> 1. Maintaining a safe/healthy operating margin that leaves room for fluctuations in input costs. 2. To protect against changes in key commodity prices like steel: adopt a practice similar to companies that add a separate line to their invoices called “Raw Materials Surcharge”, which reflects the actual increases in costs of input materials. This will negate the need to adjust the price list as certain tariffs may prove to be temporary,

²³ <https://kpidashboards.com/kpi/industry/manufacturing/>

	and materials costs could also increase further, so the best way to adjust for this in the short term is to add the increase as a separate line. 3. To protect against increases in prices of input components, (a) have a backup supplier to rely on; (b) learn to build more and more component in-house – as the team has already developed this capability for the most expensive items.
Reputational Risk	Because of the Triple Bottom Line and CSR emphasis and nature of the business, this risk is minimal and building good will and a strong brand are the best ways to mitigate reputational damage in case it occurs.
Fluctuations in CAD vs other currencies	Sell to a geographically diversified customer base; continue to develop technology to make components in-house over time.

Governing Rules and Regulations

The list of governing rules and regulations, as well as permits and licences to be obtained before starting this business, were obtained from BizPal’s repository of Business Permits and Licences for businesses as pertaining to manufacturing of heavy machinery in Ontario, e.g. the city of Hamilton as a potential home to the factory.²⁴

The full list of the dozens of applicable regulatory items can be found by going to BizPal website. The following are the general categories. The complete list is comprised of 21 municipal permits, 25 provincial permits, and 13 federal permits.

- Starting or managing a business (general)
- Serving, selling, exporting, importing
- Construction, development and zoning
- Electrical, plumbing, heating, pools, etc.
- Using roads, sidewalks, and public facilities
- Vehicles, watercraft and aircraft
- Manufacturing or processing food or goods
- Business and professional services
- Dangerous goods and waste
- Natural Resources

Each province has its own set of regulations governing the Heavy Machinery Manufacturing sector. The set of regulations for each province will be consulted and adhered to upon execution of our business plan.

²⁴ <https://services.bizpal-perle.ca/step3/?b=35&j=Hamilton%2C+Ontario&sgc=3525005&s=Machinery+manufacturing&naics=333&p=>

Investment Schedule

Please see Appendix A for important assumptions and background information. Note that all figures on this page are in CAD.

Allocation of Funds

In this section we shall see how funds will be allocated and used in the start-up process. The following table summarizes the start-up funds needed for this venture:

<u>Cash on Hand</u>	
Cash to last 4 Months (includes salaries, marketing, etc.)	421,229
Assumes founders will postpone their first year salaries	
<u>Expenses</u>	
Leasehold improvements	80,000
Patenting in Canada and the US	20,000
Professional Logo and Branding	5,000
Trademarking Logo & Name in Canada	1,400
Trademarking Logo & Name in the US	1,400
Hiring Process (ads, literature)	1,000
Stationery	1,000
Incorporation	1,000
<u>Prepaid Utilities</u>	
Prepaid rent and deposit (equal to 4 months' rent)	56,667
Prepaid utilities	2,000
<u>Capital Expenditure</u>	
Initial inventory - Enough to fulfill first order	216,000
Equipment (incl. delivery) - Complete list in report	65,000
<i>Funds Needed for Venture:</i>	
	871,696
<u>Source of Funds</u>	
Paid in Capital	348,678
Loan amount	523,018

The founders will provide 40% of startup expenses until company reaches profitability. Furthermore, they will withhold their first year salaries and receive it in years 2 and 3.

Financial Projections

Cost Structure

As previously listed under Production Parts, the direct cost of materials that go into every complete solution is close to \$216,000. At \$44,000 in direct labour, and a sale price of \$500,000 the contribution margin each unit brings in will be \$280,000.

Assumptions

Employee Benefits

CPP Contribution (at 5.1% per payworks.ca)	44,319
EI Contribution (at 2.268% per payworks.ca)	19,709
Vacation Pay in Ontario (at 4% for less than 4 years)	34,760
Extended health insurance at \$400/month/employee	81,600
Total Benefits:	180,388
Total salaries and benefits:	1,049,388

Rent

Gross Rent PSF (CAD) - includes NET and TMI	10
Area	17,000
Monthly Rent	14,167
Annual Rent	170,000

Marketing

Tradeshows - booth fee, travel, giveaways, help	50,000
Print Ads in Industry Publications	10,000
Online Ads - relevant online communities and PPC platforms	50,000
Website improvement, promotion and optimization	10,000
Branding/PR Firm Services	20,000
Marketing Total:	140,000

Depreciation

Equipment Depreciated at 10% per year	35,000
Equipment Depreciated at 20% per year	30,000
Depreciation Expense from category A	3,500
Depreciation Expense from category B	6,000
Depreciation Total:	9,500

Other Operating Expenses

CCTV Monitoring and Security (outsourced)	50,000
Utilities (heating, lighting, telecom, welding) - see Appendix C	18,000
Insurance	12,000
Other Operating Expenses Total:	80,000

Interest is assumed to be 7% on the borrowed amount of \$593,000 in the form of equipment financing loans, initial parts financing, and LHI loan.

Breakeven Analysis

Accounting Breakeven Calculation

Fixed Operating Costs / Year - Excl. Direct Labour: Only 1 general labourer assumed	1,244,888
Fixed Interest Costs per Year	31,249
Direct Material costs to Produce 1 unit	216,000
Direct Labour (all welder labour is captured here)	44,000
Sale Price of each Unit	500,000
Contribution Margin	284,000
Breakeven Number of Products to Sell	4.5
Which rounds up to the following number of units:	5.0

Cashflow Breakeven Calculation

Fixed Cash Outflow per year will be: Fixed Operating Expenses <u>plus</u> loan payments <u>less</u> Depreciation	
Therefore, total cash outflows for the year will be:	1,328,886
And, postponing salary withdrawal by founders reduces the above to:	1,058,886
Hence, fixed annual cash outflows given above assumptions is:	1,058,886
Contribution margin from each product sold	284,000
Cashflow Breakeven # Units to Sell	3.73
Which means the following number of units:	4.0

5-Year Pro Forma Income Statement

	Year				
	1	2	3	4	5
# Units Manufactured and Sold	5	6	7	8	9
Revenues	2,500,000	3,000,000	3,500,000	4,000,000	4,500,000
Direct Materials	1,080,000	1,296,000	1,512,000	1,728,000	1,944,000
Direct Labour	220,000	264,000	308,000	352,000	396,000
Gross Profit	1,200,000	1,440,000	1,680,000	1,920,000	2,160,000
Operating Expenses					
Salaries (excl. direct labour)	665,000	665,000	665,000	665,000	665,000
CPP, EI, Benefits	132,122	132,122	132,122	132,122	132,122
Rent	170,000	170,000	170,000	170,000	170,000
Marketing	140,000	140,000	140,000	140,000	140,000
Depreciation	9,500	9,500	9,500	9,500	9,500
Other Operating Expenses	80,000	80,000	80,000	80,000	80,000
Operating Profit	3,378	243,378	483,378	723,378	963,378
Interest Expense	31,249	29,978	25,386	20,463	15,183
Net Before Tax Income	- 27,871	213,399	457,991	702,915	948,195
Corporate Tax Payable	-	23,191	57,249	113,229	174,549
Net After Tax Income	- 27,871	190,208	400,742	589,686	773,646
Net Profit Margin (After Tax)	-1%	6%	11%	15%	17%

5-Year Pro Forma Cash Flow Statement

	Year				
	1	2	3	4	5
Before Tax Net Income	- 27,871	213,399	457,991	702,915	948,195
Add back: Depreciation	9,500	9,500	9,500	9,500	9,500
Add back: Deferred Salaries of co-founders	270,000	-	-	-	-
Less: Salaries withheld in Yr1 being paid back	-	- 135,000	- 135,000	-	-
Less: Payments towards principal of loan	- 62,249	- 63,520	- 68,112	- 73,036	- 78,316
Net Cashflow	189,379	24,379	264,379	639,379	879,379

Summary of (Cash + Inventory) Position

	Year				
	1	2	3	4	5
Opening Balance	630,963	820,342	844,721	1,109,100	1,748,480
Net Change	189,379	24,379	264,379	639,379	879,379
Closing Balance	820,342	844,721	1,109,100	1,748,480	2,627,859

5-Year Pro Forma Balance Sheet

Assets	Opening	Balance at Year End				
		1	2	3	4	5
Current Assets						
Cash	414,963	388,342	412,721	677,100	1,316,480	2,195,859
Inventory	216,000	432,000	432,000	432,000	432,000	432,000
Prepaid Expenses	58,667	58,667	58,667	58,667	58,667	58,667
Fixed Assets						
Gross Plant, Equipment	65,000	65,000	65,000	65,000	65,000	65,000
Land	-	-	-	-	-	-
IP (at least = registration fee)	27,800	27,800	27,800	27,800	27,800	27,800
Less: Accumulated Depreciation	-	- 9,500	- 19,000	- 28,500	- 38,000	- 47,500
Total Assets	782,429	962,309	977,188	1,232,067	1,861,946	2,731,826
Liabilities & Shareholders' Equity						
	Opening	1	2	3	4	5
Current Liabilities						
Taxes Payable	-	-	23,191	57,249	113,229	174,549
Long Term Liabilities						
Bank Loan	519,258	457,009	393,489	325,376	252,341	174,025
Shareholders' Equity						
Paid in Capital	346,172	346,172	346,172	346,172	346,172	346,172
Retained Earnings	- 83,000	159,128	214,337	503,270	1,150,205	2,037,080
<i>Total Shareholder's Equity</i>	<i>263,172</i>	<i>505,300</i>	<i>560,508</i>	<i>849,442</i>	<i>1,496,377</i>	<i>2,383,252</i>
Total Liab. & Shareholders' Equity	782,429	962,309	977,188	1,232,067	1,861,946	2,731,826

Appendix A – Assumptions Behind Financial Projections

- Average delivery fee for factory equipment is estimated at 10%. This is based on delivery quotations from some of the manufacturers.
- Average delivery fee for input materials that go into every product is estimated at 5%. This is because these will be ordered for multiple units at a time, and will be bundled for transit from major European and Asian ports for cost savings.
- It is assumed that the commercial loan taken will have a term and amortization period of 7 years an interest rate of 7% with payments made on a monthly basis at the beginning of every month.

Monthly Loan Payment		# Years					
		5	6	7	8	9	10
Rate	6.0%	9,989	8,563	7,548	6,790	6,203	5,736
	6.5%	10,105	8,682	7,669	6,913	6,329	5,864
	7.0%	10,222	8,801	7,792	7,038	6,456	5,994

- Corporate Income Tax Calculations²⁵ - 12.5% - Small business tax rate for income under 500k and 25.0% - For portion of income that exceeds 500k, for manufacturers
- No SR&ED Claims/Deductions have been assumed, even though they will be applied for and reduce the corporation's taxes payable.
- In order to help the corporation with its Cash Flow position, the salary of the 4 founders will be withheld in Year 1, but in Years 2 and 3, not only will their regular salary be paid out, but in each of these two years, half of the owed salary will also be released to them. This is reflected in our Cash Flow Projections.
- To keep financial projections simple and to the point, we have omitted A/R and A/P lines from the pro forma balance sheet.
- The growing inventory volumes required to support increasing number of units produced will be easily supported by the net earnings of the corporation; each unit only takes 3-4 months to build, and with cash flow breakeven number of units at 3 and profitability breakeven number of units at 4 units, the payment received for each delivery will fund replenishing input materials for future orders. The inventory on hand at any point in time will represent the number of units being built contemporaneously, which, given our modest sales forecasts will not exceed 2 machines at a time, even though the facility and organizational structure allows for 5 units to be worked on at the same time.
- Note that it has been calculated that the close to 50% of the \$1.8M required startup funds, will be sourced in the form of a 7-year bank loan (at 7%) that needs to be fully paid back within 7 years. However, a more optimistic scenario will unfold if the owners purchase property in Canada, and are able to obtain a secured line of credit, which not only will be at a much lower

²⁵ <https://www.bdo.ca/en-ca/insights/tax/tax-facts/corporate-income-tax-facts/>

interest rate, but repayment of the principal can then be pushed back to whenever is most convenient – in order to provide the company with added financial strength in order for it to enter different geographic markets and establish itself early on. This move would reduce expenses and significantly help with cash flow as well.

- The following is the breakdown of operating expenses. Breakdown for Salaries is presented under the Staffing section of this document. These expenses can support building up to 5 units per year. Each welder can make up to 3 units per year (we have provisioned 2 initially), and each general labourer can support production of 1 to 2 units per year. In our projections, these additional Direct Labour costs have been fully captured as the number of units exceeds 5 per year.

All financial figures are reported in CAD.

Appendix B – Pre- and Post-Treatment Analysis of Treatment

In this section we will first provide scientifically and lab-measured chemical properties of the manure pre-treatment and post-treatment. The analysis of these lab results, which reflects on our process maintaining the nutritional integrity of the input follows. Any deficiencies in the final output (whether solid fertilizer or liquid fertilizer) can be adjusted using additives – which can result in the exact levels of nutrients, pH, and other parameters as required by the customer. For **Solid Waste** we have:

Chemical Properties	Solid Animal Waste Before Treatment	Solid Animal Waste After Treatment	Comments
N	0.14%	0.7%	NPK the higher the better
P	2.2%	2.4%	NPK the higher the better
K	0.009%	2.55%	NPK the higher the better
pH (1/10)	8.25	8	Basic near neutral pH desired
EC (ms) (1/10)	1.8	4.9	Usually between 1 and 4%. Some situations can reach 5%
Fe	0.1%	0.14%	Essential trace element for plants
Cu	0.0001%	0.001%	Essential trace element for plants
Mn	0.0001%	0.0001%	Essential trace element for plants
Zn	0.0001%	0.0001%	Essential trace element for plants
OC	7.64%	7.8%	Greater than 2% desired
C/N	54/57	11/14	Decent Fertilizer: 5 to 20 percent Greater than 10 desired

Microbes	Solid Waste Before Treatment Propagule Level (CFU)	Possibility of Disease	Solid Waste After Treatment Propagule Level (CFU)	Possibility of Disease	Comments
Fungi	40%	Medium	0	None	Potential for transmission of pathogens to crops and then to humans exists
Bacteria	70%	High	0	None	Potential for transmission of pathogens to crops and then to humans exists

For **liquid waste**:

Chemical Properties	Liquid Animal Waste Before Treatment	Liquid Animal Waste After Treatment	Comments
N	0.46%	0.61%	NPK the higher the better
P	1.3%	1.5%	NPK the higher the better
K	0.08%	0.0001%	NPK the higher the better
pH (1/5)	7.96	7	Basic near neutral pH desired
EC (ms) (1/5)	2	4.5	Usually between 1 and 4%. Some situations can reach 5%
Fe	0.04%	0.04%	Essential trace element for plants
Cu	0.0001%	0.001%	Essential trace element for plants
Mn	0.0001%	0.0001%	Essential trace element for plants
Zn	0.0001%	0.02%	Essential trace element for plants
OC	7.8%	0.74%	Greater than 2% desired
C/N	16/95	1/21	Liquid fertilizer: usually value less than 5%

Microbes	Liquid Waste Pre-Treatment Propagule Level (CFU)	Possibility of Disease	Liquid Waste Post-Treatment Propagule Level (CFU)	Possibility of Disease	Comments
Fungi	30%	Medium	0	None	Potential for transmission of pathogens to crops and then to humans exists
Bacteria	80%	High	0	None	Potential for transmission of pathogens to crops and then to humans exists

The different parameters of pre-treatment and post treatment solid and liquid manures are analyzed below. The analysis shows that the manure treatment results in complete eradication of pathogens (bacteria and fungi) in both solid and liquid manures, which eliminates the possibility of transmission of pathogens to crops and humans.

Moreover, in regard to NPK (Nitrogen, Phosphorus, Potassium) values, which represent the value of the three macro-nutrients used by plants (generally the higher the better), the manure treatment process is found to increase N and K significantly, and P slightly in solid manure. As for liquid manure, the treatment is found to slightly increase N, and P, while resulted in a negligible decrease in the potassium content, which was close to zero anyway in the pre-treatment manure.

Regarding pH, the pH of post-treatment manures (both solid and liquid) decreased modestly, which makes them more suitable for wider range of crops.

Regarding Electrical Conductivity (EC), the treatment of both solid and liquid manures, caused a significant increase in EC within its optimum range of 1.1-5.7 mS, where higher values are found to be beneficial for plant growth.

Regarding Organic Carbon (OC) content, the solid and liquid manure treatments had different outcomes, as in solid manure it caused a slight increase in OC content, while in liquid manure it caused a significant decrease in OC content. Since, the OC content of post-treatment liquid manure (0.74%) was above the minimum OC levels seen in typical agricultural soils (0.7%), the decrease seen in the OC content during the liquid manure processing is not considered a significant problem.

As for C/N ratio, both solid and liquid treatments caused a significant decrease in the C/N ratio. The both C/N ratios fall between 1 and 15, which is found to cause rapid mineralization and release of Nitrogen (N), a key macronutrient for plants.

Microbial Activity Analysis

Both solid and liquid manure treatment resulted in complete eradication of bacteria and fungi present in the manure samples. This is a significant finding as the potential for transmission of pathogens to crops and humans exist. Some recent outbreaks of human enteric pathogens have been traced back to fresh produce contaminated in the field by animal manure or improperly produced compost (Sivapalasigam et al. 2004; US FDA 2007; CDC 2006)²⁶. Manure and improperly composted manure can be a source of pathogen contamination on crop products intended for human consumption. Pathogens have the potential to cause human illness when consumers are exposed to them.²⁷

Limitations of composting include; leaching of liquid from the compost pile to underground springs and surrounding surface waters, odor pollution, serve as attraction sites for vectors, creates dust, which can cause allergic reactions when inhaled by humans, loss of nutrients such as nitrogen, causes ammonia and carbon dioxide (a green house gas) emission into the environment, compost materials might be

²⁶ https://tigerprints.clemson.edu/cgi/viewcontent.cgi?article=2123&context=all_theses

²⁷ <http://www.omafra.gov.on.ca/english/engineer/facts/05-021.htm#why>

washed by run-off into water bodies, the lack of available labor, time, equipment and land for storage and operations.²⁸

However, gamma, alpha and UV irradiation of manure are only acceptable theoretical physical methods of pathogen control. They are very cost-intensive and cannot be economically appropriate for use by small-scale farmers.²⁹

Organic fertilizer contains carbon as part of its chemical makeup; and **it is the carbon**, along with nitrogen, phosphorus and potassium that **feeds microbes** and enables them to make nutrients available for plants in a naturally occurring biological process.³⁰

NPK Analysis

- Pre-treatment Solid Manure NPK value: 0.14:2.2:0.009
- Post-Treatment Solid Manure NPK value: 0.7:2.4:2.55
- Pre-treatment Liquid Manure NPK Value: 0.46:1.3:0.08
- Post-treatment Liquid Manure NPK Value: 0.61:1.5:0

The benefits of the Manure Treatment Machine regarding NPK values of solid manure are:

- 1) Increasing the Nitrogen (N) content by 5 folds or by more than 0.5 percentage point.
- 2) Increasing the Phosphorous (P) content by 0.2 percentage point (slight increase)
- 3) Increasing the Potassium (K) content by more than 28000 folds or by more than 2.5 percentage points.

The NPK value of the post-treatment solid manure (0.7:2.4:2.5), is considered within the expected range (0.5-1.5) with respect to N, and above the expected range for P (0.2-0.7) and K (0.5-2). These expected ranges are for fresh cattle manure. These data confirm the superiority of our post-treatment manure compared to fresh cattle manure with respect to NPK values.

It is important to note that since the N value of our pre-treatment solid manure (0.14) was less than the expected value (0.5-1.5) for a fresh manure, it shows that our source of fresh manure for treatment was not optimum/typical with respect to the N value. Thereby, with the 5-fold increase seen in N content during the manure processing, it is very possible to see significantly higher N value than 0.7 for our post-treatment manure if we change the source of our manure.

The benefits of the Manure Treatment Machine regarding NPK values of liquid manure are:

- 1) Increasing the Nitrogen (N) content by 0.15 percentage point (slight increase).
- 2) Increasing the Phosphorous (P) content by 0.2 percentage point (slight increase).
- 3) No significant change (**even a decrease is seen**) with respect to the K value.

The NPK value of the post-treatment liquid manure (0.61:1.5:0), is not optimum with respect to K content, when compared to NPK values of fresh cattle manure. The cause of it is that the initial (pre-treatment) K content was almost zero from the beginning and thereby its processing could not significantly change the K value.

²⁸ <https://www.ncbi.nlm.nih.gov/pmc/articles/PMC5036676/>

²⁹ <https://www.ncbi.nlm.nih.gov/pmc/articles/PMC5036676/>

³⁰ <https://www.holganix.com/blog/8-advantages-and-disadvantages-of-using-organic-fertilizer>

Trace Minerals Analysis

Solid Manure: Fe and Cu content increased by 40% and 900% respectively during solid manure treatment. No significant changes were observed for Mn and Zn.

Liquid Manure: Cu and Zn content increased by 900% and 19900 % respectively during liquid manure treatment. No significant changes were observed for Fe and Mn.

It is important to note that the trace minerals content in the pre-treatment manure for both solid and liquid forms was less than the expected amount. Nonetheless, it is the change in mineral contents, rather than the absolute values, that matter most when evaluating the manure treatment process.

pH Analysis

Regarding pH, solid manure treatment resulted in a decrease in pH of 0.25 (from 8.25 to 8). Liquid manure treatment resulted in a decrease in pH of 1 (from 8 to 7). In both instances the manure has become more acidic. It is important to note that the desirable pH range for optimum plant growth varies among crops. While some crops grow best in the 6.0 to 7.0 range, others grow well under slightly acidic conditions.³¹ Thereby, given the relatively basic pH of fresh manure (between 7.5 and 8), our manure processing which slightly increases the acidity of the manure, makes it more suitable for a wider range of crops³².

If it turns out the soil is too alkaline, the acid level can be increased by mixing in materials such as peat moss or soil sulfur.³³

EC (Electrical Conductivity) Analysis

Regarding EC (mS), solid and liquid manure treatments both resulted in an increase in EC (ms) values. An increase of 3.1 mS (milliSiemens) from 1.8 to 4.9 mS, and an increase of 2.5 mS from 2 to 4.5 mS were observed in solid and liquid manure treatments, respectively. Optimal EC levels in the soil range from 1.1-5.7 mS, with higher values indicating more nutrient availability.³⁴ Therefore, our manure processing enhances the EC of the fertilizer within the optimal range, which is beneficial for plant growth.

1 milliSiemens = 1 mS = 1 mS/cm = 1 mMho = 1 mMho/cm = 1 dS/m = 1,000 μ S (microSiemens) = 1,000 μ S/cm³⁵

Organic Carbon (OC) Analysis:

Regarding OC, solid manure treatment resulted in minor increase in OC content, from 7.64% to 7.8%. As for liquid manure treatment, the OC content decreased significantly from 7.8% to **0.74%**, a decrease of almost 7 percentage points. It is important to note that soil organic carbon threshold for sustaining soil

³¹ <https://www.cropnutrition.com/nutrient-management/soil-ph>

³² <https://www.ncbi.nlm.nih.gov/pmc/articles/PMC5467826/>

³³ <https://drearth.com/living-feed/the-technology/perfect-ph/>

³⁴ <http://traceandsave.com/what-can-electrical-conductivity-tell-us-about-our-soil/>

³⁵ <https://gpnmag.com/article/figuring-out-fertilization/>

quality is widely suggested to be about 2%, below which deterioration may occur.³⁶ However, the organic carbon content of agricultural soils in Western Australia is found to be between 0.7% and 4%. This suggests that our post treatment liquid manure which saw a dramatic decrease of OC content (to 0.74%), still has an acceptable level of Organic Carbon (OC).³⁷

C/N Ratio Analysis

Regarding C/N, solid manure treatment resulted in almost 80% decrease in the C/N value, with the final value being 11.14. As for liquid manure treatment, it resulted in 93% decrease in the C/N value, with the final value being 1.21. When an organic fertilizer has a C/N ratio between 1 and 15, rapid mineralization and release of N occurs, which is available for plant uptake. The lower the C:N ratio, the more rapidly nitrogen will be released into the soil for immediate crop use.³⁸ In our case, the post-treatment solid and liquid manures have C/N ratios between 1 and 15, which suggests rapid mineralization and release of N from the fertilizer. Moreover, the perfect balance of carbon to nitrogen falls between an 8:1 ratio and a 15:1 ratio, and our post-treatment solid fertilizer which has a C/N ratio of 11.14 falls within this range.³⁹

³⁶ [https://www.researchgate.net/post/Is there any optimum range for organic carbon found in tropical soils](https://www.researchgate.net/post/Is_there_any_optimum_range_for_organic_carbon_found_in_tropical_soils)

³⁷ <https://www.agric.wa.gov.au/measuring-and-assessing-soils/what-soil-organic-carbon>

³⁸ <https://www.sciencedirect.com/topics/agricultural-and-biological-sciences/carbon-to-nitrogen-ratio>

³⁹ <https://ampagronomy.com/managing-cn-ratios-in-our-soils/#:~:text=The%20problem%20with%20that%20is,carbon%20and%20one%20part%20nitrogen.>

Appendix C – Advantages of Organic over Chemical Fertilizers

- In addition to releasing nutrients, as organic fertilizers break down, they improve the structure of the soil and increase its ability to hold water and nutrients. Over time, organic fertilizers will make your soil—and plants—healthy and strong.
- Since they are the ultimate slow-release fertilizers, it's very difficult to over fertilize (and harm) your plants.
- There's little to no risk of toxic buildups of chemicals and salts that can be deadly to plants.
- Organic fertilizers are renewable, biodegradable, sustainable, and environmentally friendly.
- Although rather expensive in packages, you can make your own organic fertilizer by composting or find inexpensive sources—such as local dairy farms—that may sell composted manure.

One of the commonly cited disadvantages of organic fertilizers, however, is that the chemical composition (i.e. NPK values) are “not known”. However, with new technology, the exact nutrient amounts of the output can be measured and any adjustments can be made using additives.

Advantages of Chemical Fertilizer:

- Since nutrients are available to the plants immediately, improvement occurs in days.
- They are highly analyzed to produce the exact ratio of nutrients desired.
- Standardized labeling makes ratios and chemical sources easy to understand.
- They're inexpensive.

Disadvantages of Chemical Fertilizer:

- Chemical fertilizers are primarily made from nonrenewable sources, including fossil fuels.
- They grow plants but do nothing to sustain the soil. The fillers do not promote life or soil health, and even packages labeled “complete” do not include the decaying matter necessary to improve soil structure. In fact, chemical fertilizers don't replace many trace elements that are gradually depleted by repeated crop plantings, resulting in long-term damage to the soil.
- Because the nutrients are readily available, there is a danger of over fertilization. This not only can kill plants but upset the entire ecosystem.
- Chemical fertilizers tend to leach, or filter away from the plants, requiring additional applications.

- Repeated applications may result in a toxic buildup of chemicals such as arsenic, cadmium, and uranium in the soil. These toxic chemicals can eventually make their way into your fruits and vegetables.
- Long-term use of chemical fertilizer can change the soil pH, upset beneficial microbial ecosystems, increase pests, and even contribute to the release of greenhouse gases.

Why Organic?

Plants can't tell if the nitrogen, or other essential nutrients, they are taking up came from an organic or chemical source, but choosing an organic over chemical fertilizer does have an impact on the health of your vegetables, your soil and groundwater.

Organic fertilizers actually improve the soil, while chemical or synthetic fertilizers deplete the soil over the long run.

Organic Fertilizers

- Release nutrients slowly, providing a steady flow of plant nutrients
- Non-burning (won't harm delicate seedling roots)
- Improve soil structure
- Increase water holding capacity
- Increase nutrient holding capacity
- Promotes earthworms and soil micro-organisms
- Buffers soil from chemical imbalances

Chemical Fertilizers

- Release nutrients rapidly
- May burn plants (and harm delicate seedling roots)
- Leaching can pollute groundwater
- Loss of fertilizer due to leaching means soil requires many applications
- Can make soil toxic after continuous use
- Mineral salts can build up over time and kill off soil microbes
- High nitrogen levels may repel earthworms⁴⁰

⁴⁰ <https://www.planetnatural.com/fertilizer-guide/>

Appendix D – Real Estate Costs

The following properties are sampled from within Ontario to represent costs of purchasing/leasing real estate with Heavy Industrial zoning. These can be used as reference for estimation.

PURCHASE

Location: Oldcastle (near Windsor):

Area: 16,050 SF

Sales Price: \$1,450,000

Source URL: https://www.remax.ca/commercial/on/oldcastle-real-estate/5160-ure-wp_id233077611-lst

LEASE – SAMPLE 1

Location: Stoney Creek (near Hamilton)

Area: 18,600 SF (5% office space)

Lease Rate: \$6.9 PSF NET + \$2 TMI = **\$8.9 PSF**

Source URL: <http://www.collierscanada.com/23925#.XLsy7OgzbZt>

LEASE – SAMPLE 2

Location: Cambridge

Area: 23,144 SF

Lease Rate: \$6.75 PSF NET + \$3.5 additional rent = **\$10.25 PSF**

Source URL: <http://www.collierscanada.com/26634#.XLszhugzbZt>

Appendix E – Resumes

MOHSEN KHALAJ

Email: Khalajm52@yahoo.com

Phone: +98 9123477016

Website: www.tolouemazraetalaie.com

Address: 71, Salehi Fashami Alley, Saeed Arab st, Damavand st,
Tehran, Iran.

Zip code: 1745834387

EDUCATION

- BA in Optometry, SHAHID BEHESHTI UNIVERSITY OF MEDICAL SCIENCES, Tehran - 2016
- AA in Optics, UNIVERSITY of APPLIED SCIENCE, Tehran - 2008
- DIPLOMA in Auto Mechanic, TECHNICAL HIGH SCHOOL OF RAHBAR ENGHELAB, Tehran - 1992

PROFESSIONAL EXPERIENCE

- CEO and Technical Director at ToloueMazraeTalaie Company – since January 2020
- Technical Manager of the Optometry and Glasses Manufacturing Department of ShahidBeheshti Clinic for 2 years, since 2018
- Technical Manager of the Optometry and Glasses Manufacturing Department of 9 Dey Clinic for 3 years, 2015 to 2018
- Technical Manager of the Optometry and Glasses Manufacturing Department of Khanevadeh Clinic for 8 years, since 2012
- Management of the Workshop for Making and Cutting Medical Glasses and Sun Glasses, since 1999
- Technical Manager of Besat Hospital Glasses Manufacturing Department for 11 years, 2002 to 2013
- Responsible for Following and Producing Industrial Machines at Park Sabz Shahin and Pardis Novin Gostar Companies, 2010 to 2015
- Making Glasses and Selling Medical and Sun glasses for 25 years – since 1995
- Contracting with the Social Security Organization, Armed Forces Insurance and Banks

RESEARCH / FIELD WORK EXPERIENCE

- Impact of Different Waves and Frequencies and UV Rays on the Micro Organism

INNOVATIONS / INVENTIONS

Electronic Animal Waste Purifier Machine (EAWP) that Convert the Animal Liquid Waste in to an Enriched Agricultural Water Which is Odorless and Without any Viruses as well as the Animal Solid Waste Which is Contamination-Free and Used as Animals , Poultry and Fish Feed and also as an Enriched Fertilizer, December 2019

CERTIFICATES

- Auto Mechanical Internship, 1991 – TECHNICAL and VOCATIONAL CENTRE, TEHRAN
- Business License from Tehran Glasses Manufacturers Union
- Certificate of Skill in the field of Cutting around Glasses – Technical and Vocational Centre, Tehran – 2002
- Retraining and Learning of Glasses Manufacturing under the Supervision of the Iranian Ophthalmological Association, Tehran 2010
- Certificate of Retraining and Learning of Medical Lenses from Carl Zeiss, Germany

LANGUAGES

- Farsi Native
- English at Level B2 with a Band Score of 5

ALI REZA MORADGHOLI

Email: Ford7251@yahoo.com

Phone: +98 9125083458

Website: www.tolouemazraetalaie.com

Address: 4, Sina Alley, Apt2, Vali Asr, Tehran, Iran

Zip code: 1335863951

EDUCATION

- BA in English Literature, September 1997 – AZAD UNIVERSITY, SOUTH BRANCH of TEHRAN
- AA in Teaching English Language, July 1993 – BALAL HABASHI TEACHER TRAINING CENTRE, Tehran
- DIPLOMA in Science, September 1991 – ENGHELAB ESLAMI SENIOR HIGH SCHOOL, Tehran

PROFESSIONAL EXPERIENCE

- Director of Sales and Marketing, TEHRAN at ToloueMazraeTalaie, January 2020 – up to now
- Financial Manager, TEHRAN at ToloueMazraeTalaie, January 2020 – up to now
- Research and Development Expert, TEHRAN at Pardis Novin Gostar Pasargad, May 2012 – March 2015
- Educational Deputy in High School, TEHRAN at 15 District, September 2011 – June 2020
- Teacher of the Ministry of Education with Excellent Rank, TEHRAN at 15 District, September 1993 – September 2011
- Teaching English at Sadat Institute, TEHRAN , June 1995 – September 2005
- Participated in the Iranian – German conference, TEHRAN at Shohadaye Kargar School, May 2010

RESEARCH / FIELD WORK EXPERIENCE

- THE GLOBAL ENVIRONMENTAL PROTECTION AWARENESS WORKSHOP, Tehran, May 2010
- THE USE OF CLEAN ENERGY WORKSHOP, Tehran, May 2010

INNOVATIONS / INVENTIONS

Electronic Animal Waste Purifier Machine (EAWP) that Convert the Animal Liquid Waste in to an Enriched Agricultural Water Which is Odorless and Without any Viruses as well as the Animal Solid Waste Which is Contamination-Free and Used as Animals , Poultry and Fish Feed and also as an Enriched Fertilizer, December 2019

CERTIFICATES

- ICDL Courses in Computer, 2005 , Tehran
(INTERNET – WORD – ACCESS – EXCEL – POWER POINT)
- Basic Concepts of Information and Communication Technology ,2004 , Tehran
- Using a Computer and Managing Files ,2004 , Tehran
- Emerging Diseases and Ways to Prevent Them, 2009, Tehran
- Principles and Goals of Education, 2009, Tehran
- Teacher’s Social, Educational and Administrative Rights, 2009, Tehran
- Generalities of Developmental Psychology,2010, Tehran
- Curriculum Analysis, 2009 , Tehran

PUBLICATIONS

1. COLLECTOR and TRANSLATOR of THE BOOK, “**THE MOST COMPLETE GOLDEN REFERENCE of THE INTERNET**”, 2003

LANGUAGES

- Farsi Native
- English at Level B2 with a Band Score of 5.5

MAHTAB RASHVAND

Email: rashvand1996@yahoo.com

Phone: +98 9129223862

Website: www.tolouemazraetalaie.com

Address: 66, Southern Bakhtiari st, Apt4, Narmak, Tehran, Iran

Zip code: 1646948516

EDUCATION

- BA in Midwifery, November 2018 – AZAD UNIVERSITY OF TEHRAN MEDICAL SCIENCES BRANCH
- Pre University in Science, August 2014 – SALAM PREUNIVERSITY CENTRE, Tehran
- DIPLOMA in Science, June 2013 – SALAM SENIOR HIGH SCHOOL, Tehran

PROFESSIONAL EXPERIENCE

- Administrative and H R Manager at ToloueMazraeTalaie Company – since January 2020
- Director of Research and Development at ToloueMazraeTalaie Company – since January 2020
- Four Swimming Skills at the Level of Coaching and Lifeguarding
- Perform All Emergency Matters such as ECG – Vaccination – Stitches – Medical Information
 - Injections
- Internship in More than 80 Natural Childbirth in Tehran Hospitals under the Supervision of University Professors
- Training and Cares Before and After Childbirth

RESEARCH / FIELD WORK EXPERIENCE

- In the Field of Hygiene and Laboratory Tests Related to the Invention of Animal Waste Purifier Machine
- Liquid and Solid Fertilizer and Hydroponic Production since 2017
- Recycling Medical Needle Syringe Parts

INNOVATIONS / INVENTIONS

Electronic Animal Waste Purifier Machine (EAWP) that Convert the Animal Liquid Waste in to an Enriched Agricultural Water Which is Odorless and Without any Viruses as well as the Animal Solid Waste Which is Contamination-Free and Used as Animals , Poultry and Fish Feed and also as an Enriched Fertilizer, December 2019

CERTIFICATES

- PREGNANCY TRAINING INSTRUCTOR, October 2019 – TEHRAN UNIVERSITY of MEDICAL SCIENCES JAHAD, Tehran
- ESSAY WRITING COURSE WORKSHOP, TEHRAN UNIVERSITY of MEDICAL SCIENCES JAHAD, Tehran
- MIDWIFERY OFFICE PERMIT, September 2019 – ORGANIZATION of the MEDICAL SYSTEM of the ISLAMIC REPUBLIC of IRAN - Tehran
- HEALTH BASE COURSES in IRAN – UNDER the SUPERVISION of SHAHID BEHESHTY, Tehran
- M.H.L.E in LANGUAGE, October 2019 – IRAN’s HEALTH MINISTRY, Tehran

PUBLICATIONS

- History of Midwifery and Job Memories of Colleagues

MEMBERSHIPS / AFFILIATIONS

- The Medical System of the Islamic Republic of Iran – Medical System Number M – 57590
- Iranian Scientific Midwifery Association

LANGUAGES

- Farsi Native
- English at Level C1 with a Band Score of 7

ALI RASHVAND

Email:AliRashvand_1352@yahoo.com

Phone:+98 9123439523

Website: www.tolouemazraetalaie.com

Address: 66, Southern Bakhtiari st, Apt4, Narmak, Tehran, Iran

Zip code: 1646948516

EDUCATION

- BA in science, September 1997 – AZAD UNIVERSITY OF SHAHR E REY
- AA in Science, September 1994 – TEACHER’S TRAINING CENTER OF DASTGHEIB, Tehran
- DIPLOMA in Science, June 1992 – SENIOR HIGH SCHOOL OF ENGHELAB ESLAMI, Tehran

PROFESSIONAL EXPERIENCE

- Chairman of the Board at ToloueMazraeTalaie Company – since January 2020
- Production and Executive Director at ToloueMazraeTalaie Company – since January 2020
- Teacher of the Ministry of Education with Excellent Rank, TEHRAN at 15 District, since September 1992
- Project Manager and CEO and Investor to Build More than 200 Housing Units, TEHRAN, since 1996
- All Services Related to Glass, Doors and Windows of the Buildings since 1989
- Technical Manager of the Medical Glasses Workshop since 2006

RESEARCH / FIELD WORK EXPERIENCE

- Agriculture, Livestock and Recycling since 2017
- Liquid and Solid Fertilizer and Hydroponic Production since 2017
- Solar Furnaces and Reducing Energy Costs in Heat Production since 1998
- Use Concave Mirrors to Focus Heat and Generate Hot Water and Electricity since 1998

INNOVATIONS / INVENTIONS

Electronic Animal Waste Purifier Machine (EAWP) that Convert the Animal Liquid Waste in to an Enriched Agricultural Water Which is Odorless and Without any Viruses as well as the Animal Solid Waste Which is Contamination-Free and Used as Animals , Poultry and Fish Feed and also as an Enriched Fertilizer, December 2019

CERTIFICATES

- ENTREPRENEURSHIP, June 2019 – PLANNING and H R and INFORMATION TECHNOLOGY CENTRE, Tehran
- ENTREPRENEURSHIP, May 2019 – FACULTY of ENTREPRENEURSHIP, UNIVERSITY of TEHRAN
- PERMISSION to BUILD GLASS and MIRROR, DOORS and WINDOWS WORKSHOP, February 2011
- OPTOMETRY, May 2020 - FACULTY of ENTREPRENEURSHIP, SHARIF UNIVERSITY JAHAD, TEHRAN
- ICDL Courses in Computer 2004 - 2005 – IN-SERVICE TRAINING COURSES, Tehran (INTERNET – WORD – ACCESS – EXCEL – POWER POINT)
- BASIC CONCEPTS of INFORMATION and COMMUNICATION TECHNOLOGY – 2004
- USING a COMPUTER and MANAGING FILES – 2004
- FUNDAMENTALS and PRINCIPLES of MANAGEMENT – 2011
- SCHOOL SMARTENING STRATEGIES – 2018
- FIRST AID and EMERGENCY MEDICAL CARE – 2016
- PREPARE and DEAL with NATURAL and UNEXPECTED EVENTS – 2017
- SUPPORT for INDUSTRIAL PRODUCTS – 2019
- ENTREPRENEURSHIP ROADMAP and CREATING and MANAGING SMALL BUSINESSES – 2019
- PREVENTION of ACUTE RESPIRATORY DISEASES (COVID – 19) – 2020
- REVIEWS of REOPENING of PUBLIC PLACES and SCHOOLS in the EPIDEMIC of ACUTE DISEASES - 2020

MEMBERSHIPS / AFFILIATIONS

- Joined NGO Group at POUYESH JAHADGARAN SALAMAT in Corona (COVID – 19)

LANGUAGES

- Farsi Native
- English at Level B2 with a Band Score of 5

